

METRIC PAN HEAD MACHINE SCREWS

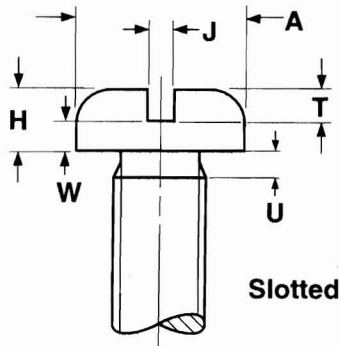

Slotted

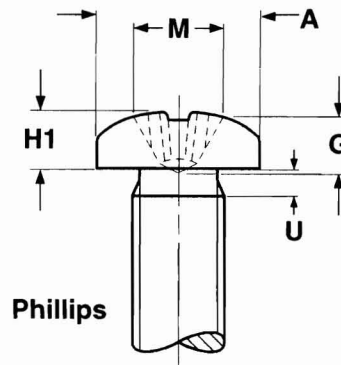

Phillips

METRIC - SLOTTED PAN HEAD MACHINE SCREWS

| Nominal Size | Thread Pitch | A | | H | | J | | T | W | U |
|--------------|--------------|---------------|-------|-------------|------|---------------|------|---------------|----------------|---------------|
| | | Head Diameter | | Head Height | | Width of Slot | | Depth of Slot | Wall Thickness | Thread Runout |
| | | Max | Min | Max | Min | Max | Min | Min | Min | Max |
| M1.6 | 0.35 | 3.2 | 2.9 | 1.00 | 0.86 | 0.60 | 0.46 | 0.35 | 0.3 | 0.7 |
| M2 | 0.4 | 4.0 | 3.7 | 1.30 | 1.16 | 0.70 | 0.56 | 0.5 | 0.4 | 0.8 |
| M2.5 | 0.45 | 5.0 | 4.7 | 1.50 | 1.36 | 0.80 | 0.66 | 0.6 | 0.5 | 0.9 |
| M3 | 0.5 | 5.6 | 5.3 | 1.80 | 1.66 | 1.00 | 0.86 | 0.7 | 0.7 | 1 |
| M4 | 0.7 | 8.00 | 7.64 | 2.40 | 2.26 | 1.51 | 1.26 | 1 | 1 | 1.4 |
| M5 | 0.8 | 9.50 | 9.14 | 3.00 | 2.86 | 1.51 | 1.26 | 1.2 | 1.2 | 1.6 |
| M6 | 1 | 12.00 | 11.57 | 3.6 | 3.3 | 1.91 | 1.66 | 1.4 | 1.4 | 2 |
| M8 | 1.25 | 16.00 | 15.57 | 4.8 | 4.5 | 2.31 | 2.06 | 1.9 | 1.9 | 2.5 |
| M10 | 1.5 | 20.00 | 19.48 | 6.0 | 5.7 | 2.81 | 2.56 | 2.4 | 2.4 | 3 |

METRIC - PHILLIPS PAN HEAD MACHINE SCREWS

| Nominal Size | Thread Pitch | A | | H1 | | M | G | | U | Phillips Driver Size |
|--------------|--------------|---------------|-------|----------------|------|-----------------|--------------------|------|---------------|----------------------|
| | | Head Diameter | | Height of Head | | Recess Diameter | Recess Penetration | | Thread Runout | |
| | | Max | Min | Max | Min | Ref | Max | Min | Max | |
| M1.6 | 0.35 | 3.2 | 2.9 | 1.30 | 1.16 | 1.7 | 0.95 | 0.70 | 0.7 | 0 |
| M2 | 0.4 | 4.0 | 3.7 | 1.60 | 1.46 | 1.9 | 1.2 | 0.9 | 0.8 | 0 |
| M2.5 | 0.45 | 5.0 | 4.7 | 2.10 | 1.96 | 2.7 | 1.55 | 1.15 | 0.9 | 1 |
| M3 | 0.5 | 5.6 | 5.3 | 2.40 | 2.26 | 3 | 1.8 | 1.4 | 1 | 1 |
| M3.5 | 0.6 | 7.00 | 6.64 | 2.60 | 2.46 | 3.9 | 1.9 | 1.4 | 1.2 | 2 |
| M4 | 0.7 | 8.00 | 7.64 | 3.10 | 2.92 | 4.4 | 2.4 | 1.9 | 1.4 | 2 |
| M5 | 0.8 | 9.50 | 9.14 | 3.70 | 3.52 | 4.9 | 2.9 | 2.4 | 1.6 | 2 |
| M6 | 1 | 12.00 | 11.57 | 4.6 | 4.3 | 6.9 | 3.6 | 3.1 | 2 | 3 |
| M8 | 1.25 | 16.00 | 15.57 | 6.0 | 5.7 | 9 | 4.6 | 4.0 | 2.5 | 4 |
| M10 | 1.5 | 20.00 | 19.48 | 7.50 | 7.14 | 10.1 | 5.8 | 5.2 | 3 | 4 |